

NEW PROCEDURES — Stewardess training supervisor Mary King (second from left) explains the passenger service unit of the DC-9 to North Central stewardesses acquainting themselves with the new aircraft. From left are Gail Pederson, Mary King, Sylvia Patenaude, and Connie Jungbluth. The service unit controls reading lights, stewardess call button and oxygen for each passenger.



REAL THING — All equipment on the new DC-9 stewardess trainer is fully operable, including the buffet unit, being explained by Mary King, training supervisor (right) to stewardess Gail Pederson.



AIRPLANE GENERAL -- GALLEYS

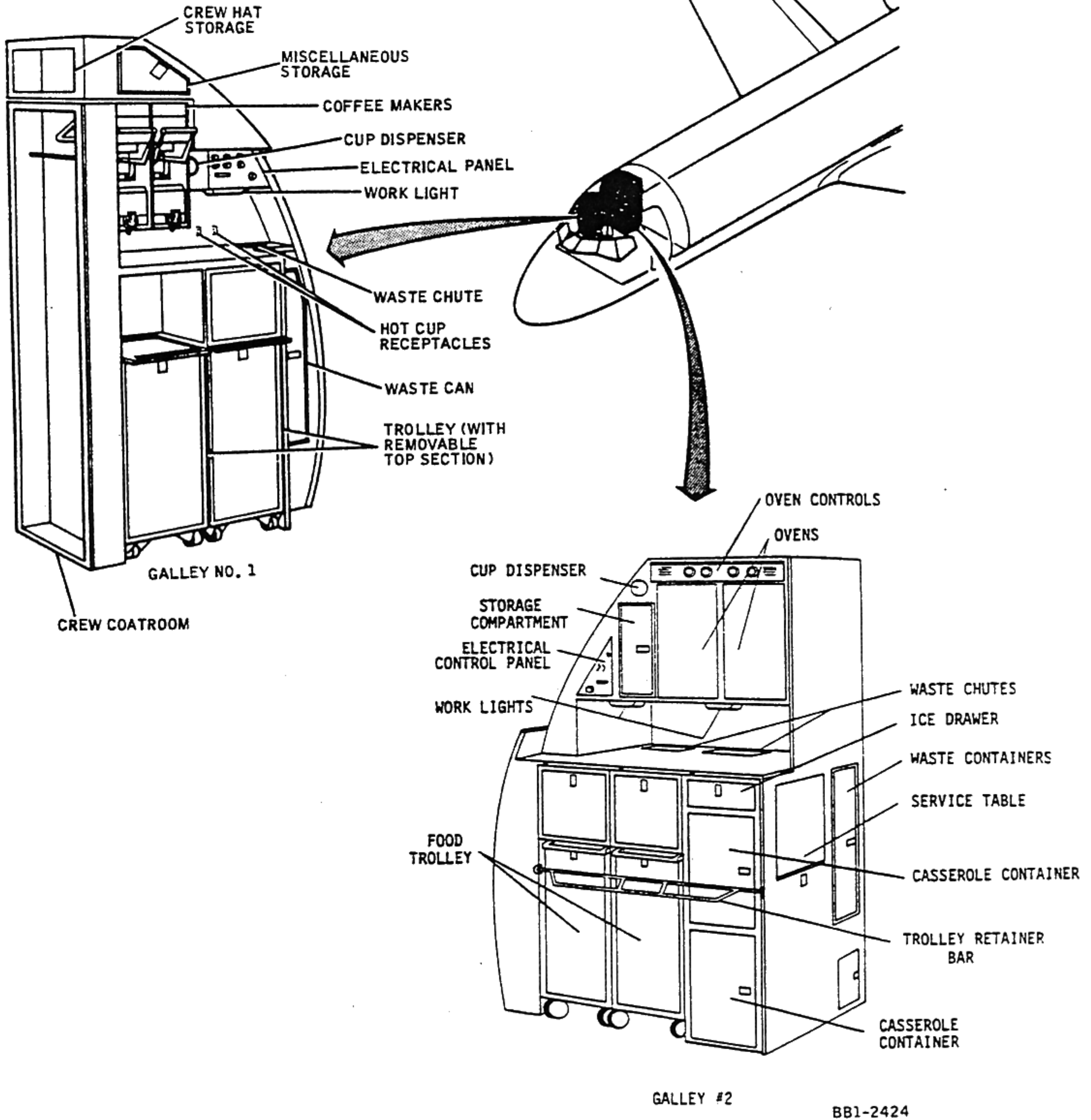



AIRPLANE GENERAL -- GALLEYS (-50)

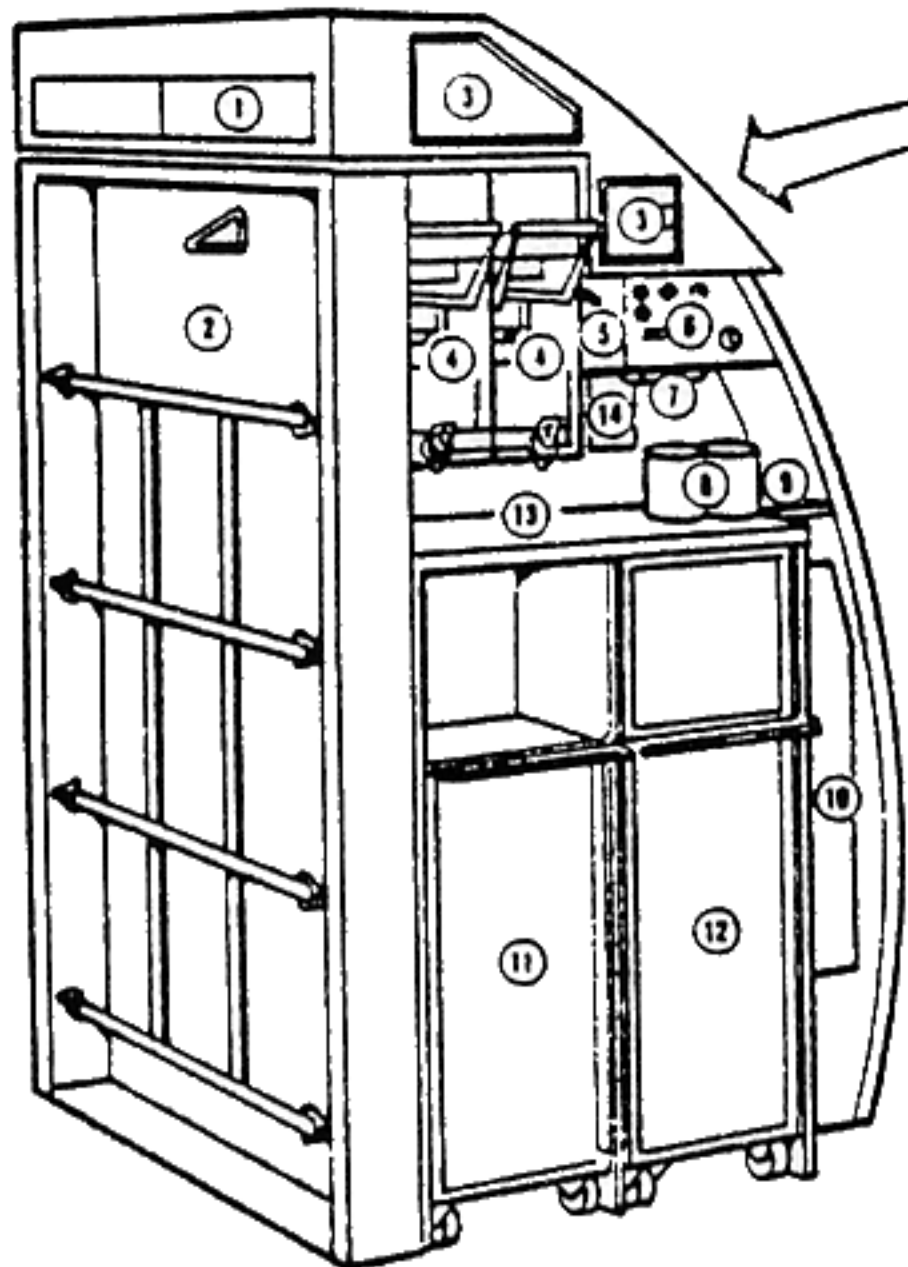

GALLEY UNIT NO. 1

- | | |
|--------------------------|---------------------|
| 1. CREW HAT STORAGE | 8. HOT CUPS |
| 2. CREW COATROOM | 9. WASTE CHUTES |
| 3. MISCELLANEOUS STORAGE | 10. WASTE CONTAINER |
| 4. COFFEE MAKERS | 11. MEAL CART |
| 5. CUP DISPENSER | 12. BEVERAGE CART |
| 6. ELECTRICAL PANEL | 13. WORK COUNTER |
| 7. WORK LIGHTS | 14. HOT CUP TIMER |

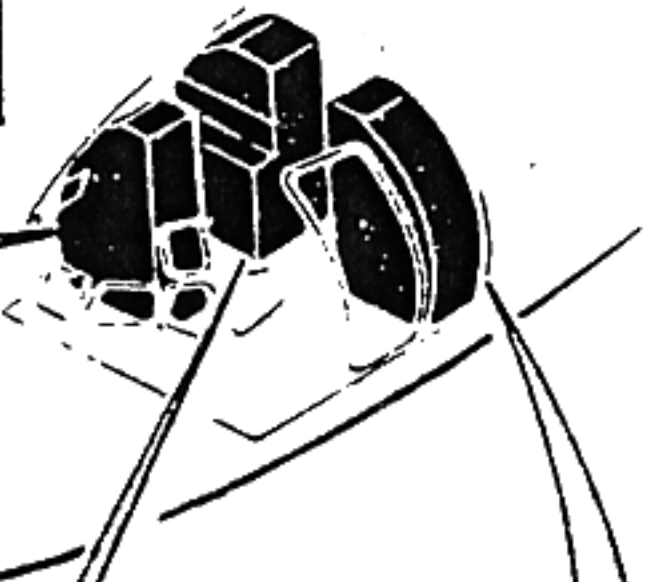

- CO2 FIRE EXTINGUISHER
- 1 - WATER FIRE EXTINGUISHER

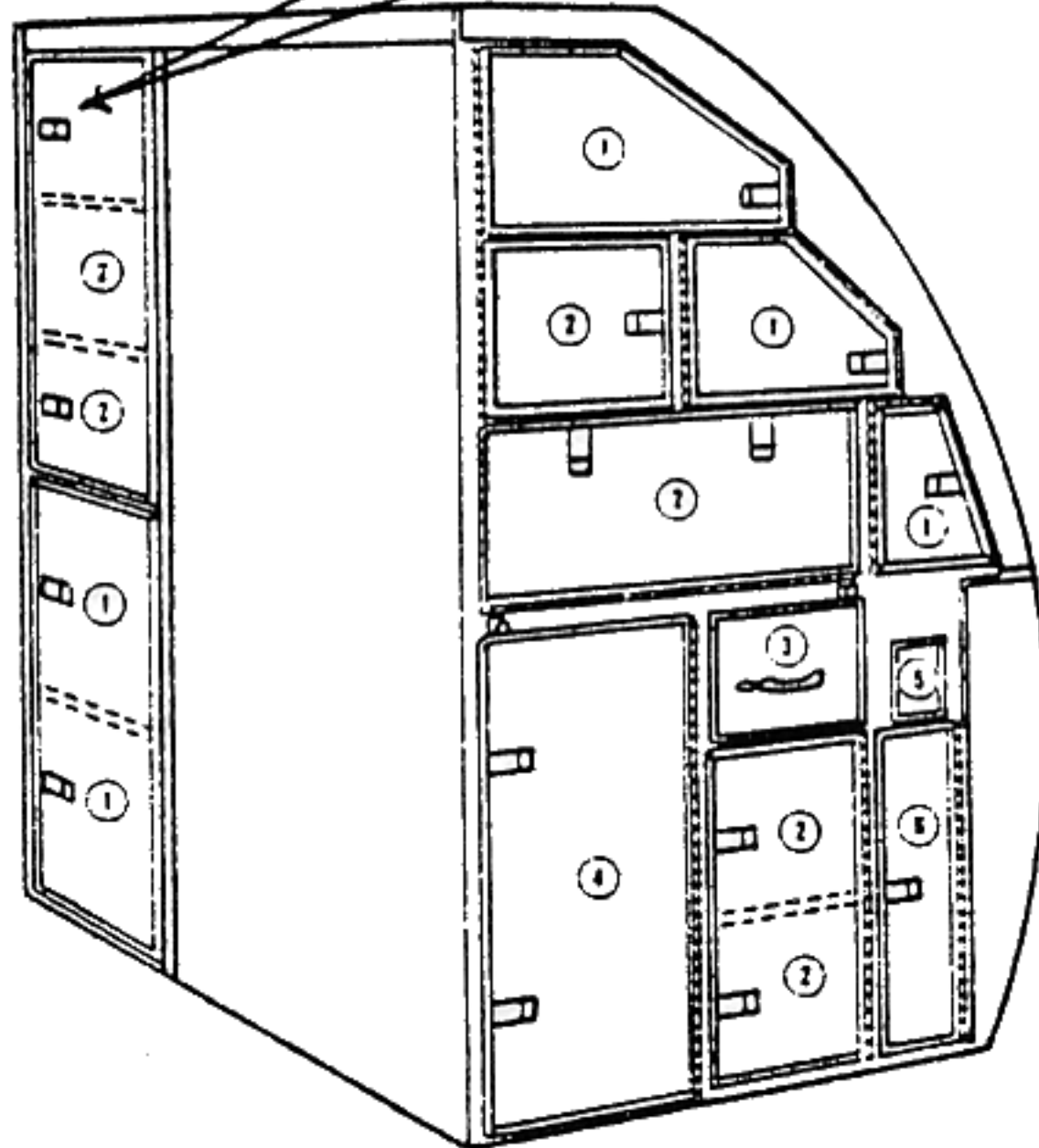

GALLEY UNIT NO. 3

- 1. MISCELLANEOUS STOWAGE
- 2. TRAY CARRIER COMPARTMENT
- 3. STORAGE DRAWER
- 4. BEVERAGE CART
- 5. WASTE CHUTE
- 6. WASTE CONTAINER

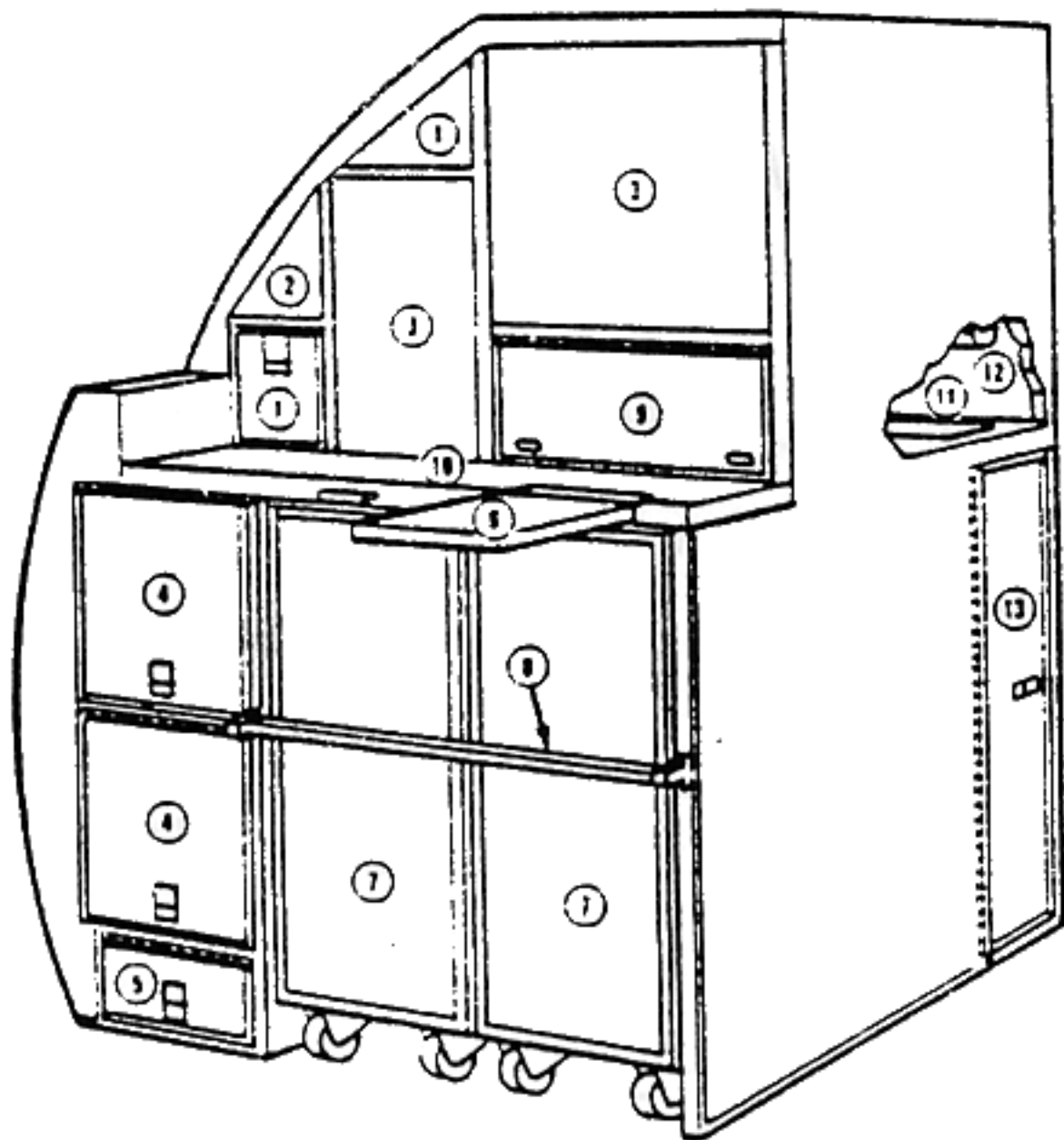

GALLEY UNIT NO. 2

- 1. MISCELLANEOUS STOWAGE
- 2. ELECTRICAL PANEL
- 3. OVEN
- 4. CASSEROLE CARRIER COMPARTMENT
- 5. AUXILIARY TABLE STOWAGE COMPARTMENT
- 6. AUXILIARY TABLE
- 7. FOOD CART
- 8. CART LOCKING BAR
- 9. WORK COUNTER DOOR
- 10. WORK COUNTER
- 11. WASTE CHUTE
- 12. WORK LIGHT
- 13. WASTE CONTAINER